

**JOSCO**

EST.  
1977

# SURFACE FINISHING CATALOGUE





# CONTENTS

## **POWER BRUSHWARE**

- Pipeline Wheel Brushes
- Wheel Brushes
- Bevel Brushes
- Cup Brushes
- High Speed Wheel Brushes
- Spindle Mounted Wheel Brushes
- Spindle Mounted Bevel Brushes
- High Speed Cup Brushes
- Spindle Mounted Cup Brushes
- Tube Brushes
- Kits

## **REINFORCED ABRASIVES**

- Cut-Off Discs
- Grinding Discs

## **BONDED ABRASIVES**

- Mounted Points

## **COATED ABRASIVES**

- Flap Discs
- Flap Wheels
- Drum Spindles

## **NON WOVEN ABRASIVES**

- Strip-It Discs
- Strip-It Wheels
- Flap Discs
- Surface Conditioning Discs

## **POLISHING**

- Bufs
- Spindle Mounted Bufs
- Tapered Spindles
- Polishing Compounds
- Grinding Pastes
- Lapping Compounds
- Stripe Removal Wheels
- Kits

The Josco Brush Catalogue includes a number of new and improved products and features to ensure that our brushes last longer and perform better for our customers.

## Wheel Brushes

### Increased Wire Density

Many new additions have been made to Josco's range of Crimped Wire Wheel Brushes.

You will find a more sizes and widths than ever before - all with increased wire density which will help to make your brush perform better and last longer.

## New Wire Types

New wire types include the Extra Tough Brass Coated TC Wire for long life aggression and heavy duty brushing applications.

To see all of our featured wire types and a full selection guide to find what best suits your application, please take a look at our Technical Information section.

## New High Speed Wheel Brush Range Spindle-Mounted

The 230 series of decarbonising spindle-mounted wheel brushes are now high speed rated and are ideal for decarbonising in automotive applications.

## Improved Drive Mechanism

### Hex Drive

Take a look at our new and improved crimped and twistknot cup brushes, constructed with a hex drive.

## Wider Range

The Josco Brush Catalogue features a much wider range including new twistknot wheel brushes, spindle-mounted end and cup brushes, as well as hand brushes.

## New Wire Colour Coding System

Red Powder Coating = Steel Wire

Green Powder Coating = Stainless Steel Wire

Orange Powder Coating = Brass Wire



## Rotation Speed

Under working conditions, the centrifugal force built up by a revolving brush is quite high. The wires or materials used in the brush become considerably stiffer at the working face, and the cutting or abrasive action of the brush is greatly increased. It follows that, as the speed increases, so the cutting action is faster. At the same time, harsh action is increased, and therefore light gauge wires often give better results at high speeds than coarse wires running slowly.

## Work Holder or Fixtures

Automatic fixtures are now quite commonly made and used in connection with standard brushing operations, and it is a fact that under some conditions, much better results are achieved when the work to be brushed is held either in a small hand-held fixture or in an automatic fixture. Where extreme uniformity of finish is required, roller or controlled feed of the material to the brush is most effective.

## Pressure Needed When Applying Work to Brush

For cleaning, roughing, and deburring at high speeds, use light pressure. For finishing, polishing and brushing at low speeds with wire, sufficient pressure may be needed to bring the sides of the wire in contact with the work.

## Brush Wear

To achieve the longest life out of the brush, it is recommended that the rotation should be reversed from time to time. When rotating in one direction only, the cutting edge of the wires become dulled, and by reversing the brush, better cutting action is noticed.

## Safety

For the safest operating conditions, operators and those standing in close vicinity of the operator and workpiece should wear goggles and protective clothing.

## Special Brushes

Our standard lines of power brushes meet most requirements, but nevertheless, we do appreciate the need for special types. If you have these special requirements, we shall always be pleased to co-operate with you in making a product or suggesting a method.

## Testing on the job

A brush should always be tested on the job to secure the best results. It is recommended that you do a test patch on your work piece (preferably on a spot that is not easily visible) to see if the brush is right for your project.

## Brushing Recommendations

If you have any brushing problems, you may wish to write to us at [customerservice@josco.com.au](mailto:customerservice@josco.com.au) for advice on the best brush for your job. To enable us to tackle your problem efficiently, please provide the following details:

- A description of the article you wish to brush – the size, shape and material, with material if possible, a sample of the part to be brushed.
- A description of the work to be done and the surface of the finish required.
- The horsepower available.
- Maximum speed of your equipment.
- Arbor hole or shaft size of your equipment.
- The maximum diameter of brush which can be mounted on your machine.

**For further brushing recommendations and technical information on brush types, please skip to the end of the catalogue.**



## Wire Type Key

Wire Type	Description
<b>Crimped HD</b>	Suitable for light surface treatment and flexible brushing and deburring applications.
<b>Twistknot HD</b>	A standard twistknot wire used for heavy duty brushing applications.
<b>XHD</b>	Twistknot XHD wire is a premium tenacious wire providing a faster, more aggressive cut together with longer life. Provides increased durability and is better suited to extreme brushing requirements.
<b>TNC</b>	Straight and single crimp tin coated wire suited to deburring and decarbonising.
<b>TNCE</b>	Straight and single crimp tin coated wire suited to deburring and decarbonising with a TNC encapsulated elastomer to prevent wire breakage.
<b>BC Steel Wire</b>	Crimped brass coated steel wire provides high tensile strength and cutting performance and is used for demanding brushing and deburring applications.
<b>BCTC</b>	Brass coated tyre cord steel wire provides long life aggression and is used for heavy duty brush applications.
<b>316SS</b>	Premium stainless steel wire ideal for Australian conditions. Increased resistance to corrosion in marine environments. Used for brushing stainless steel and aluminium.
<b>302SS/304SS</b>	Lower grade than 316SS. Use on 302/304 stainless steel in non-marine environments.
<b>Brass</b>	Ideal for surface finishing on copper and brass. Non-sparking.
<b>Abrasive Nylon</b>	Abrasive impregnated nylon filament for corrosion and paint removal on a wide range of materials.

## Fill Selection Guide

Fill	APPLICATION SURFACE							
	Steel	Stainless Steel	Brass	Aluminium	Copper	Iron	Plastic	Wood
<b>Crimped HD</b>	BC	NR	SC	NR	NR	BC	SC	SC
<b>Twistknot HD</b>	BC	NR	SC	NR	NR	BC	SC	SC
<b>Twistknot XHD</b>	BC	NR	SC	NR	NR	BC	SC	SC
<b>TNC</b>	BC	NR	SC	NR	NR	BC	SC	SC
<b>TNCE</b>	BC	NR	SC	NR	NR	BC	SC	SC
<b>BCHD</b>	BC	NR	SC	NR	NR	BC	SC	SC
<b>BCTC</b>	BC	NR	SC	NR	NR	BC	SC	SC
<b>SS 316</b>	NR	BC	SC	BC	NR	NR	SC	SC
<b>SS 302/304</b>	NR	SC	SC	BC	NR	NR	SC	SC
<b>Brass</b>	SC	SC	BC	SC	BC	SC	SC	SC
<b>Abrasive Nylon</b>	SC	SC	NR	SC	SC	SC	BC	BC

### Fill Selection Guide Key

BC = Best Combination

SC = Suitable Combination

NR = Not recommended



## Bore and Thread Key

Type	Description
<b>MB</b>	Multibore (Fits 12mm, 1/2", 16mm, 5/8", 3/4" and 7/8")
<b>MT</b>	Multi-thread (M10 and M14)
<b>M10</b>	Suits 100mm Angle Grinders
<b>M14</b>	Suits most other 115mm to 230mm Angle Grinders
<b>5/8W</b>	5/8 Whitworth

## Wire Gauge Conversion Chart

Wire gauge is a unit of measure that denotes the diameter of wire, either in diameter or a cross-sectional area.

Standard Wire Gauge (S.W.G)	Diameter
22	0.80mm
26	0.50mm
30	0.35mm

## Packaging Types



Clamshell

Box

## Product Accessories



Multibore (MB)  
Reducing Bush

Multi-thread (MT)  
Adaptor



# WHEEL BRUSHES



852508



102

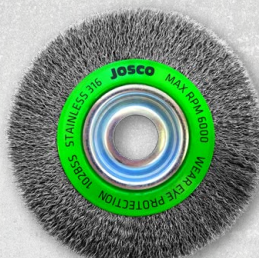

102BSS



103ABR

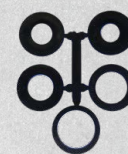

Multibore (MB)  
Reducing Brush

## Crimped Wheel Brushes

Josco Wheel Brushes with crimped wire are suitable for bench grinders. Crimped wire construction allows for softer brushing and light paint and rust removal.



Part No.	Dia.	Width	Bore	Wire Size	Material	Max. RPM	Inner QTY	Outer QTY	Pack Type
99A	75	16	13	0.30	HD Steel Wire	8,000	2	10	Clamshell
852508	85	25	8	0.30	HD Steel Wire	3,000	10	10	Box
851313	85	13	12.7	0.30	HD Steel Wire	3,000	10	10	Box
100A	100	12	MB	0.30	HD Steel Wire	6,000	2	10	Clamshell
100B	100	19	MB	0.30	HD Steel Wire	6,000	2	10	Clamshell
100	100	25	MB	0.30	HD Steel Wire	6,000	2	10	Clamshell
101B	125	19	MB	0.35	HD Steel Wire	6,000	2	10	Clamshell
101	125	25	MB	0.35	HD Steel Wire	6,000	2	10	Clamshell
102A	150	12	MB	0.35	HD Steel Wire	6,000	2	30	Box
102B	150	22	MB	0.35	HD Steel Wire	6,000	2	10	Clamshell
102BSS	150	19	MB	0.35	316 Stainless	6,000	2	2	Clamshell
102BBR	150	19	MB	0.30	Brass Wire	6,000	2	2	Box
102	150	25	MB	0.35	HD Steel Wire	6,000	2	10	Clamshell
102SS	150	25	MB	0.35	316 Stainless	6,000	2	10	Clamshell
103A	200	19	MB	0.35	HD Steel Wire	4,600	5	10	Clamshell
103ASS	200	19	MB	0.30	316 Stainless	4,600	2	2	Clamshell
103ABR	200	19	MB	0.30	Brass Wire	4,600	5	5	Box
103	200	28	MB	0.35	HD Steel Wire	4,600	5	10	Clamshell
103SS	200	28	MB	0.30	316 Stainless	4,600	2	2	Box
103B	200	38	MB	0.35	HD Steel Wire	4,600	5	10	Box
103C	200	50	MB	0.35	HD Steel Wire	4,600	5	10	Box
104	250	19	25.4	0.35	HD Steel Wire	3,600	2	2	Box
104A	250	25	25.4	0.35	HD Steel Wire	3,600	5	5	Box
104B	250	38	25.4	0.35	HD Steel Wire	3,600	2	2	Box
104C	250	50	25.4	0.35	HD Steel Wire	3,600	2	2	Box
105	300	25	31.8	0.35	HD Steel Wire	3,000	2	2	Box
105A	300	38	31.8	0.35	HD Steel Wire	3,000	2	2	Box
105B	300	50	31.8	0.35	HD Steel Wire	3,000	2	2	Box





JTW100M

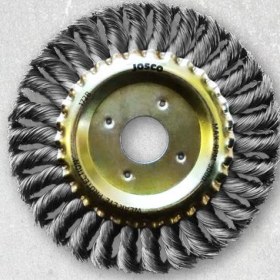

172B

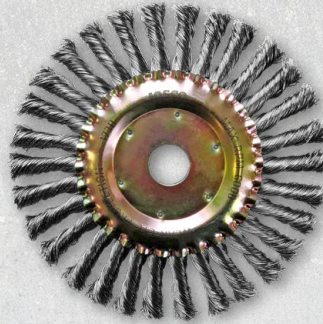

173B

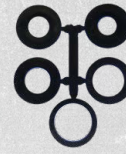

Multibore (MB)  
Reducing Bush



Multi-thread (MT)  
Adaptor

## Twistknot Wheel Brushes

Josco Wheel Brushes with twistknot wire are ideal for hard, aggressive brushing and contaminant removal. Great for scale, rust and paint removal.



Part No.	Dia.	Width	Row	Knots	Wire Size	Material	Bore	Max. RPM	Inner QTY	Outer QTY	Pack Type
<b>171</b>	100	12	1	20	0.35	XHD Steel	MB	12,000	2	20	Clamshell
<b>171B</b>	100	12	1	20	0.50	XHD Steel	MB	12,000	2	20	Clamshell
<b>171BSS</b>	100	12	1	20	0.50	316 Stainless	MB	12,000	2	20	Clamshell
<b>JTW100M</b>	100	12	1	20	0.50	XHD Steel	MT	12,500	5	20	Clamshell
<b>JTW115</b>	115	12	1	20	0.50	XHD Steel	22.2	12,500	2	10	Box
<b>JTW115SS</b>	115	12	1	20	0.50	316 Stainless	22.2	12,500	2	10	Box
<b>JTW125</b>	125	13	1	30	0.50	XHD Steel	22.2	12,000	2	10	Box
<b>JTW125SS</b>	125	13	1	30	0.50	316 Stainless	22.2	12,000	2	10	Box
<b>JTW1253</b>	125	13	1	30	0.50	XHD Steel	M14	12,500	2	20	Clamshell
<b>172B</b>	150	13	1	30	0.50	XHD Steel	MB	9,000	2	10	Box
<b>172BSS</b>	150	13	1	30	0.50	316 Stainless	MB	9,000	1	5	Box
<b>172C</b>	150	25	2	30	0.50	XHD Steel	MB	9,000	10	10	Box
<b>JTW1503</b>	150	13	1	30	0.50	XHD Steel	M14	9,000	2	10	Clamshell
<b>173B</b>	200	13	1	30	0.50	XHD Steel	MB	6,000	5	5	Box
<b>173A</b>	200	26	2	30	0.35	XHD Steel	MB	6,000	5	5	Box
<b>173C</b>	200	26	2	30	0.50	XHD Steel	MB	6,000	5	5	Box

Note: All diameter, width, bore and wire measurements shown are in millimetres (mm).





5828



582840



582840T



JS8020

## Twistknot Pipeline Wheel Brushes



Josco Tight Twistknot Wire Brushes are used in areas such as stringer bead welds, hot pass, double jointing and bevel cleaning. Josco also carry brushes for pipe coating removal, machine cleaning etc. Contact Josco for specialist assistance.

Part No.	Dia.	Width	Rows	Knots	Wire Size	Material	Bore	Max. RPM	Inner QTY	Outer QTY	Pack Type
JS9008	100	6	1	20	0.35	316 Stainless	16	12,000	2	10	Box
5828	125	6	1	30	0.50	XHD Steel	22	12,000	5	20	Box
5828T	125	6	1	30	0.50	XHD Steel	M14	12,000	5	20	Box
582840	125	6	1	40	0.50	XHD Steel	22	12,000	5	20	Box
582840T	125	6	1	40	0.50	XHD Steel	M14	12,000	5	20	Box
5828SS	125	6	1	30	0.50	316 Stainless	22	12,000	5	20	Box
5828TSS	125	6	1	30	0.50	316 Stainless	M14	12,000	5	20	Box
4009	150	6	1	30	0.80	XHD Steel	22	9,000	2	10	Box
JS8020	178	6	1	60	0.50	XHD Steel	22	9,000	2	10	Box
JS80203	178	6	1	60	0.50	XHD Steel	M14	9,000	2	10	Box
JS8021	178	6	1	76	0.50	XHD Steel	22	9,000	2	10	Box
JS80323	178	8	1	36	0.50	XHD Steel	M14	9,000	2	10	Box



JCB100TC



JCB100SS

## Crimped Bevel Brushes



Josco Bevel Brushes are designed specifically for brushing in 'hard-to-reach' workpiece areas. The bevel design allows the brush to be operated either as a flat brush or a "wheel" brush.

Part No.	Dia.	Width	Wire Size	Thread	Material	Max. RPM	Inner QTY	Outer QTY	Pack Type
JCB100TC	100	20	0.30	MT	BCTC Wire	12,500	3	30	Clamshell
JCB100SS	100	20	0.30	MT	316 Stainless	12,500	3	30	Clamshell



TB100M



TB100MSS



TB1153



TB1253



Multi-thread (MT)  
Adaptor

## Twistknot Bevel Brushes



Josco Bevel Brushes are designed specifically for brushing in 'hard-to-reach' areas of your work piece. Twistknot wire is ideal for hard, aggressive brushing and contaminant removal including scale, rust, paint and corrosion.

Part No.	Dia.	Width	Wire Size	Thread	Material	Max. RPM	Inner QTY	Outer QTY	Pack Type
TB100M	100	13	0.50	MT	XHD Steel	12,000	5	30	Clamshell
TB100MSS	100	13	0.50	MT	316 Stainless	12,000	5	5	Clamshell
TB1153	115	15	0.50	M14	XHD Steel	12,000	2	20	Clamshell
TB1153SS	115	15	0.50	M14	316 Stainless	12,000	5	5	Clamshell
TB1253	125	15	0.50	M14	XHD Steel	12,000	5	5	Clamshell
TB1503	150	15	0.50	M14	XHD Steel	9,000	5	5	Clamshell

Note: All diameter, width, bore and wire measurements shown are in millimetres (mm).



# CUP BRUSHES



## Crimped Cup Brushes



Josco Cup Brushes are available with threaded bore or spindle (please see section 5.0). The crimped wire design allows for less aggressive brushing and contaminant removal.

Part No.	Dia.	Wire Size	Thread	Material	Max. RPM	Inner QTY	Outer QTY	Pack Type
153M	75	0.30	MT	HD Steel	12,000	3	30	Clamshell
153MSS	75	0.30	MT	316 Stainless	12,000	3	30	Clamshell
153MBR	75	0.30	MT	Brass	12,000	3	30	Clamshell
153TCM	75	TC	MT	BCTC	12,000	2	10	Clamshell
1543	100	0.30	M14	HD Steel	6,000	2	10	Clamshell
1543SS	100	0.30	M14	316 Stainless	6,000	2	2	Box
1544SS	100	0.30	5/8W	316 Stainless	6,000	2	2	Box
1543BR	100	0.30	M14	Brass	6,000	2	2	Box
1553	125	0.30	M14	HD Steel	6,000	4	4	Box
1554	125	0.30	5/8W	HD Steel	6,000	2	2	Box

## Cup Brush Accessories

Part No.	Description	Inner QTY	Outer QTY	Pack Type
TBA1	Cup Brush Adaptor M14 Thread > 10 x 1.25	1	1	Loose



## Twistknot Cup Brushes



Josco Cup Brushes with twistknot wire are ideal for hard, aggressive brushing and contaminant removal. Great for scale, rust and paint removal.

Part No.	Dia.	Wire Size	Rows	Metal Skirt	Thread	Material	Max. RPM	Inner QTY	Outer QTY	Pack Type
<b>TC65M</b>	65	0.50	1	-	MT	XHD Steel	12,000	3	30	Clamshell
<b>166M</b>	75	0.35	1	-	MT	XHD Steel	12,000	3	30	Clamshell
<b>166MSS</b>	75	0.35	1	-	MT	316 Stainless	12,000	3	30	Clamshell
<b>166BM</b>	75	0.50	1	-	MT	XHD Steel	12,000	3	30	Clamshell
<b>166BMSS</b>	75	0.50	1	-	MT	316 Stainless	12,000	5	30	Clamshell
<b>159B3</b>	100	0.50	1	-	M14	XHD Steel	9,000	2	10	Clamshell
<b>159NB3</b>	100	0.50	1	Yes	M14	XHD Steel	9,000	10	10	Box
<b>159NB3SS</b>	100	0.50	1	Yes	M14	316 Stainless	9,000	2	2	Box
<b>159NB4</b>	100	0.50	1	Yes	5/8W	XHD Steel	9,000	2	2	Box
<b>160NB3</b>	100	0.50	2	Yes	M14	XHD Steel	9,000	4	4	Box
<b>160NB3SS</b>	100	0.50	2	Yes	M14	316 Stainless	9,000	2	2	Box
<b>161B3</b>	125	0.50	1	-	M14	XHD Steel	6,000	4	12	Box
<b>161NB3</b>	125	0.50	1	Yes	M14	XHD Steel	6,000	4	4	Box
<b>162NB3</b>	125	0.50	2	Yes	M14	XHD Steel	6,000	4	4	Box

### Removal of Skirt

The letter 'N' in the part numbers denotes a brush fitted with a metal skirt. The skirt can be removed when the wire is worn to the level of the skirt, thus giving longer life. Some twistknot cup brushes are supplied with a skirt to prevent wire splay when in use. When worn, the skirt may be easily removed by striking the edge with a hammer and cold chisel or welders chipping hammer, exposing additional wire for extra wear.

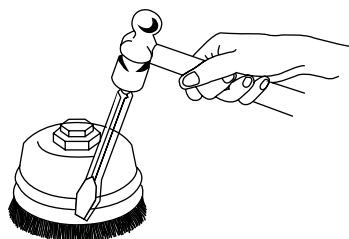

### Usage Instructions

Josco Twistknot Cup Brushes can either be used at an angle or flat to the workpiece. Brushes with 0.35mm wire are best suited to a flat application. See below for explanation.

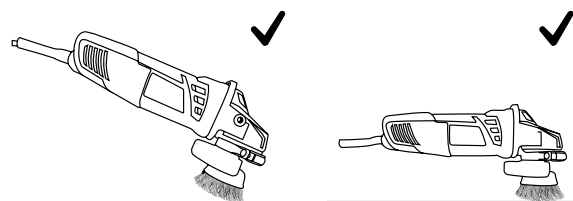



# SPINDLE MOUNTED BRUSHES



## High Speed Crimped Wheel Brushes (Decarb)



Josco High Speed Crimped Wheel Brushes are ideal for removing rust and corrosion from most metals. The 230 series decarbonising brushes are now high speed rated and ideal for decarbonising in automotive applications. For use with die grinders, air tools and drills.

Part No.	Dia.	Width	Spindle	Wire Size	Material	Max. RPM	Inner QTY	Outer QTY	Pack Type
<b>230</b>	19	6	6	0.15	HD Steel	20,000	10	10	Clamshell
<b>231</b>	25	6	6	0.20	HD Steel	20,000	10	10	Clamshell
<b>232</b>	32	6	6	0.25	HD Steel	20,000	10	10	Clamshell
<b>WC3512</b>	35	12	6.35	0.13	HD Steel	20,000	10	100	Box
<b>WC3812</b>	38	12	6.35	0.23	HD Steel	20,000	10	100	Box
<b>233</b>	38	8	6	0.25	HD Steel	18,000	10	10	Clamshell
<b>233D40</b>	40	8	6.35	0.25	HD Steel	18,000	10	10	Clamshell
<b>233D40SS</b>	40	8	6.35	0.25	316 Stainless	18,000	10	10	Clamshell
<b>234</b>	50	8	6	0.25	HD Steel	15,000	10	10	Clamshell
<b>234SS</b>	50	8	6.35	0.25	316 Stainless	15,000	10	10	Clamshell
<b>WC5010</b>	50	10	6.35	0.23	HD Steel	20,000	10	200	Box
<b>235</b>	50	19	6	0.25	HD Steel	15,000	10	10	Clamshell
<b>WC5019</b>	50	19	6.35	0.23	HD Steel	20,000	10	200	Box
<b>236</b>	50	25	6	0.25	HD Steel	15,000	10	10	Clamshell
<b>237</b>	60	15	6.35	0.25	HD Steel	15,000	10	10	Box
<b>WC6412</b>	64	12	6.35	0.29	HD Steel	20,000	10	100	Box
<b>65</b>	75	10	6.35	0.23	HD Steel	20,000	10	10	Box
<b>238</b>	80	15	6.35	0.25	HD Steel	12,000	10	10	Clamshell
<b>238BR</b>	80	15	6.35	0.30	Brass	12,000	10	10	Clamshell
<b>238SS</b>	80	15	6.35	0.25	316 Stainless	12,000	10	10	Clamshell
<b>239</b>	100	15	6.35	0.25	HD Steel	10,000	10	10	Clamshell
<b>239BR</b>	100	15	6.35	0.25	Brass	10,000	10	10	Clamshell



JCW40



JCW50



JAW100R



JAF100R

## Crimped Wheel Brushes



Josco Spindle Mounted Crimped Wheel Brushes are ideal for removing rust and paint and are fitted with a quick change 6.3mm hex shank.

Part No.	Dia.	Width	Spindle	Wire Size	Material	Max. RPM	Inner QTY	Outer QTY	Pack Type
JCW40	40	5	6.35 Hex	0.30	HD Steel	4,500	5	50	Clamshell
JCW50	50	7	6.35 Hex	0.30	HD Steel	4,500	5	50	Clamshell
JCW75	75	10	6.35 Hex	0.30	HD Steel	4,500	5	50	Clamshell
JCW100	100	13	6.35 Hex	0.30	HD Steel	4,500	5	50	Clamshell
JAW50R	50		6.35 Hex	-	Abrasive Nylon	4,500	5	100	Clamshell
JAW75R	75		6.35 Hex	-	Abrasive Nylon	4,500	5	100	Clamshell
JAW100R	100		6.35 Hex	-	Abrasive Nylon	4,500	5	100	Clamshell
JAF100R	100		6.35 Hex	-	Abrasive Nylon	4,500	5	100	Clamshell

## Abrasive Nylon Brushes

**Application:** Nylon brushes do not scratch and therefore are appropriate for cleaning and polishing of any kind of wood (fine or rustic); metallic surfaces such as automobile bodies; tile, stone and concrete; plastic materials; plus stainless steel and aluminium.

**Technical Features:** All of the nylon brushes featured in the catalogue are made of 80 grit nylon filaments impregnated with aluminium oxide abrasive particles. They have a high range of flexibility without danger of breakage, providing a long working life and an increased measure of safety. They are suitable for dry applications only, and are to be used in power drills.

**Operating Performance:** Optimum performance is obtained at the recommended working speed range of between 1,000 RPM and 2,500 RPM. Speeds above the recommended ones may smear the work piece due to heat build-up.

Note 1: All diameter, width and wire measurements shown are in millimetres (mm).  
 Note 2: Please see below for details on operating abrasive nylon brushes.



# SPINDLE MOUNTED BRUSHES



JSTW75



TC19



TBS75

## High Speed Twistknot Wheel Brushes

Josco High Speed Twistknot Wheel Brushes are ideal for use with die grinders, air tools and drills.



Part No.	Dia.	Width	Knots	Spindle	Wire Size	Material	Max. RPM	Inner QTY	Outer QTY	Pack Type
JSTW75	75	8	15	6.35	0.50	XHD Steel	20,000	2	20	Clamshell

## High Speed Twistknot Bevel Brushes

Josco High Speed Twistknot Bevel Brushes are ideal for use with die grinders, air tools and drills.



Part No.	Dia.	Width	Knots	Spindle	Wire Size	Material	Max. RPM	Inner QTY	Outer QTY	Pack Type
TBS75	75	10	15	6.35	0.50	XHD Steel	15,000	3	3	Clamshell
TBS100	100	12	18	6.35	0.50	XHD Steel	12,500	3	3	Clamshell

## High Speed Twistknot Cup Brushes

Josco High Speed Cup Brushes are ideal for use with die grinders, air tools and drills.



Part No.	Dia.	Width	Knots	Spindle	Wire Size	Material	Max. RPM	Inner QTY	Outer QTY	Pack Type
TC19	19	1	0.29	6.35	XHD Steel	22,000	10	10	30	Clamshell
TC19SS	19	1	0.29	6.35	302 Stainless	22,000	10	10	30	Clamshell
TC25	25	1	0.29	6.35	XHD Steel	22,000	10	10	30	
TC25SS	25	1	0.29	6.35	302 Stainless	22,000	10	10	30	



## Twistknot Cup Brushes

Josco Twistknot Cup Brushes are ideal for use with low speed air tools and drills for removing rust, paint and weld scale.



Part No.	Dia.	Spindle	Wire Size	Material	Max. RPM	Inner QTY	Outer QTY	Pack Type
<b>TC50</b>	50	8	0.50	XHD Steel	3,000	5	20	Clamshell

## High Speed Crimped Cup Brush

Josco Crimped Cup Brushes can be used at high speed to remove rust, paint and weld scale, and are suitable for use with die grinders, air tools and drills.



Part No.	Dia.	Spindle	Wire Size	Material	Max. RPM	Inner QTY	Outer QTY	Pack Type
<b>CC12</b>	12	6.35	0.18	HD Steel	25,000	10	10	Box
<b>CC19</b>	19	6.35	0.18	HD Steel	22,000	10	10	Box
<b>CC25</b>	25	6.35	0.18	HD Steel	22,000	10	10	Box



# SPINDLE MOUNTED BRUSHES



208 (Pointed)



220 (Flat)



240 (Busby)

## Crimped Cup Brush (Decarb)



Josco Decarbonising Crimped Cup and End Brushes are ideal for removing rust and corrosion from most metals, and decarbonising in automotive applications. Suitable for use with low speed air tools and drills.

Part No.	Dia.	Shape	Spindle	Wire Size	Material	Max. RPM	Inner QTY	Outer QTY	Pack Type
200	8	Flat	6	0.30	TNC Wire	3,000	10	10	Clamshell
201	9	Flat	6	0.30	TNC Wire	3,000	10	10	Clamshell
202	11	Flat	6	0.30	TNC Wire	3,000	10	10	Clamshell
202SS	11	Flat	6.35	0.30	316 Stainless	3,000	10	10	Clamshell
203	19	Flat	6	0.30	TNC Wire	3,000	10	10	Clamshell
204	25	Flat	6	0.30	TNC Wire	3,000	10	10	Clamshell
206	9	Pointed	6	0.30	TNC Wire	3,000	10	100	Clamshell
207	11	Pointed	6	0.30	TNC Wire	3,000	10	10	Clamshell
208	19	Pointed	6	0.30	TNC Wire	3,000	10	10	Clamshell
209	25	Pointed	6	0.30	TNC Wire	3,000	10	10	Clamshell
219	8	Flat	6 x 50	0.30	TNC Wire	3,000	10	10	Clamshell
220	8	Flat	6 x 125	0.30	TNC Wire	3,000	10	10	Clamshell
221	8	Pointed	6 x 50	0.30	TNC Wire	3,000	10	10	Clamshell
222	8	Pointed	6 x 125	0.30	TNC Wire	3,000	10	10	Clamshell
240	38	Busby	6	0.30	TNC Wire	3,000	10	10	Clamshell



## Crimped Cup Brush



Josco Crimped Cup Brushes are all fitted with a quick change 6.3mm hex shank (spindle). Suitable for use in drills.

Part No.	Dia.	Shape	Spindle	Wire Size	Material	Max. RPM	Inner QTY	Outer QTY	Pack Type
JEC17	17	Flat	6.35 Hex	0.30	HD Steel	4,500	10	50	Clamshell
JEC25	25	Flat	6.35 Hex	0.30	HD Steel	4,500	10	50	Clamshell
JEC30	30	Flat	6.35 Hex	0.30	HD Steel	4,500	5	50	Clamshell
JCC50	50	-	6.35 Hex	0.30	HD Steel	4,500	5	50	Clamshell
JCC63	63	-	6.35 Hex	0.30	HD Steel	4,500	5	50	Clamshell
JCC63SS	63	-	6.35 Hex	0.30	316 Stainless	4,500	5	50	Clamshell
JCC75	75	-	6.35 Hex	0.30	HD Steel	4,500	5	50	Clamshell
JAC25R	25	-	6.35 Hex	-	Abrasive Nylon	4,500	5	100	Clamshell
JAC50R	50	-	6.35 Hex	-	Abrasive Nylon	4,500	5	100	Clamshell
JAC75R	75	-	6.35 Hex	-	Abrasive Nylon	4,500	5	100	Clamshell



## Heavy Duty Crimped Cup Brush



Josco Heavy Duty Crimped Cup Brushes are ideal for use in low speed air tools and drills to remove rust, paint and weld scale. Their density and type of wire make these brushes suitable for heavier brushing applications.

Part No.	Dia.	Shape	Spindle	Wire Size	Material	Max. RPM	Inner QTY	Outer QTY	Pack Type
150	50	Flat	6	0.30	HD Steel	6,000	2	20	Clamshell
151GW	60	Flat	6	0.30	HD Steel	6,000	2	20	Clamshell
151BC	60	Flat	6	0.30	BC Steel	6,000	2	20	Clamshell
151TC	60	Flat	6	TC	BCTC Wire	6,000	2	20	Clamshell
152	70	-	8	0.30	BC Steel	6,000	5	20	Clamshell

Note 1: All diameter, width and wire measurements shown are in millimetres (mm).  
 Note 2: Please see below for details on operating abrasive nylon brushes.



# HAND BRUSHES



BLH3R (Long Handle)



BSH3R (Short Handle)



BSCH410

## Hand Brushes



Josco Hand Brushes are versatile tools for deburring, paint and rust removal, cleaning, edge blending and surface preparation. They are available in a range of different formations spanning across long and short handles, 3, 4 or 5 row and converged face, plus much more.

Part No.	Rows	Type	Material	Width	Inner QTY	Outer QTY	Pack Type
BLH3R	3	Long Wood	HD Steel	15	12	120	Box
BLH3RC	3 Converged	Long Wood	HD Steel	15	12	120	Box
BLH4R	4	Long Wood	HD Steel	20	12	120	Box
BLH5R	5	Long Wood	HD Steel	25	12	120	Box
402	4	Long Plastic	HD Steel	20	12	120	Box
422	4	Long Plastic	316 Stainless	20	12	120	Box
442	4	Long Plastic	Brass	20	12	120	Box
BLH3RSS	3	Long Wood	316 Stainless	15	12	120	Box
BLH4RSS	4	Long Wood	316 Stainless	20	12	120	Box
BLH4RB	4	Long Wood	Brass	20	12	120	Box
BSH3R	3	Short Wood	HD Steel	15	12	120	Box
BSH4R	4	Short Wood	HD Steel	20	12	120	Box
BSH5R	5	Short Wood	HD Steel	25	12	120	Box
BSCH410	6	Arched Wood	HD Steel	30	6	72	Box

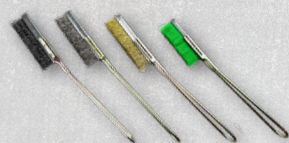

JSH65, JSH65SS, JSH65BR, JSH65N



BSBS



557

Part No.	Rows	Type	Material	Width	Inner QTY	Outer QTY	Pack Type
JSH65SS	1	Mini (65mm)	316 Stainless	6	6	60	Box
JSH65BR	1	Mini (65mm)	Brass	6	6	60	Box
JSH65	1	Mini (65mm)	HD Steel	6	6	60	Box
JSH65N	1	Mini (65mm)	Nylon	6	6	60	Box
BSBS	1	Plastic Scratch	HD Steel	15	12	120	Box
BSBB	1	Plastic Scratch	Brass	15	12	120	Box
BSBSS	1	Plastic Scratch	316 Stainless	15	12	120	Box
557	-	File Cleaning	File Card	50	10	100	Box



JHBHBS



JHBHBL



JHBBC



## Hot Bench Brush



Josco's Hot Bench Brushes are ideal for cleaning hot surfaces. With two sizes available, it is the ideal hand brush for getting into tight spots and cleaning around tools. They are naturally heat and chemical resistant, and are great for cleaning up hot areas such as welding stations, furnaces, BBQ's and wood fire ovens. They are heat resistant to 150°C, and have a flash point of 200°C.

Both the java fibre and wood handle are sustainably sourced and carry the FSC watermark to indicate ethically sourced material.

Part No.	Description	Material	Inner QTY	Outer QTY	Pack Type
JHBHBS	Small Hot Bench Brush	Java fibre	12	120	Box
JHBHBL	Large Hot Bench Brush	Java fibre	6	60	Box
JHBBC	Banister Brush	Coco fibre	12	120	Box





751



769

## Single Spiral Boiler Tube Brushes

For the removal of rust and residue from inside tubes and holes.



Part No.	Dia.	Wire Size	Ferrule Fitting	Material	Inner QTY	Outer QTY	Pack Type
750.1	22	0.30	Male 1/2 BSW	HD Steel	1	1	Box
750	25	0.30	Male 1/2 BSW	HD Steel	1	1	Box
751	31	0.30	Male 1/2 BSW	HD Steel	1	1	Box
752.1	32	0.30	Male 1/2 BSW	HD Steel	1	1	Box
752	38	0.30	Male 1/2 BSW	HD Steel	1	1	Box
753.1	41	0.30	Male 1/2 BSW	HD Steel	1	1	Box
753	44	0.30	Male 1/2 BSW	HD Steel	1	1	Box
754	50	0.30	Male 1/2 BSW	HD Steel	1	1	Box
755	56	0.30	Male 1/2 BSW	HD Steel	1	1	Box
756	63	0.30	Male 1/2 BSW	HD Steel	1	1	Box
757	67	0.30	Male 1/2 BSW	HD Steel	1	1	Box
758	75	0.30	Male 1/2 BSW	HD Steel	1	1	Box
759	81	0.30	Male 1/2 BSW	HD Steel	1	1	Box
760	88	0.30	Male 1/2 BSW	HD Steel	1	1	Box
761	94	0.30	Male 1/2 BSW	HD Steel	1	1	Box
762	100	0.30	Male 1/2 BSW	HD Steel	1	1	Box
763	125	0.30	Male 1/2 BSW	HD Steel Wire	1	1	Box
764	150	0.30	Male 1/2 BSW	HD Steel Wire	1	1	Box

## Double Spiral Boiler Tube Brushes

Double spiral construction provides greater brush density.



Part No.	Dia.	Wire Size	Ferrule Fitting	Material	Inner QTY	Outer QTY	Pack Type
765	38	0.30	Male 1/2 BSW	HD Steel	1	1	Box
766	44	0.30	Male 1/2 BSW	HD Steel	1	1	Box
767	50	0.30	Male 1/2 BSW	HD Steel	1	1	Box
768	56	0.30	Male 1/2 BSW	HD Steel	1	1	Box
769	63	0.30	Male 1/2 BSW	HD Steel	1	1	Box
770	69	0.30	Male 1/2 BSW	HD Steel	1	1	Box
771	75	0.30	Male 1/2 BSW	HD Steel	1	1	Box
772	81	0.30	Male 1/2 BSW	HD Steel	1	1	Box
773	88	0.30	Male 1/2 BSW	HD Steel	1	1	Box
774	94	0.30	Male 1/2 BSW	HD Steel	1	1	Box
775	100	0.30	Male 1/2 BSW	HD Steel	1	1	Box



JTB9010

## Single Twist Condensor Tube Brushes

For the removal of rust and residue inside of tubes and holes.



Part No.	Dia.	Wire Size	Ferrule Fitting	Material	Inner QTY	Outer QTY
JTB9010	10	0.20	¼" Hex Shank	HD Steel	6	60
JTB9013	13	0.20	¼" Hex Shank	HD Steel	6	60
JTB9016	16	0.20	¼" Hex Shank	HD Steel	6	60
JTB9019	19	0.20	¼" Hex Shank	HD Steel	6	60
JTB9025	25	0.30	¼" Hex Shank	HD Steel	6	60
JTB9032	32	0.30	¼" Hex Shank	HD Steel	6	60
776.1	6	0.30	Male 3/16 BSW	HD Steel	1	
776.2	8	0.30	Male 3/16 BSW	HD Steel	1	
776	9	0.30	Male 3/16 BSW	HD Steel	1	
777	13	0.30	Male 5/16 BSW	HD Steel	1	
776.1B	6	0.30	Male 3/16 BSW	Brass	1	
776.2B	8	0.30	Male 3/16 BSW	Brass	1	
776B	9	0.30	Male 3/16 BSW	Brass	1	
777B	13	0.30	Male 5/16 BSW	Brass	1	
776.1N	6	0.30	Male 3/16 BSW	Nylon	1	
776.2N	8	0.30	Male 3/16 BSW	Nylon	1	
776N	9	0.30	Male 3/16 BSW	Nylon	1	
777N	13	0.40	Male 5/16 BSW	Nylon	1	

Note: All diameter, width, bore and wire measurements shown are in millimetres (mm).





781B



781N

## Double Twist Condenser Tube Brushes

Double twist construction provides greater brush density.



Part No.	Dia.	Wire Size	Ferrule Fitting	Material	Inner QTY
778	16	0.30	Male 5/16 BSW	HD Steel	1
779	19	0.30	Male 5/16 BSW	HD Steel	1
780	25	0.30	Male 5/16 BSW	HD Steel	1
781	32	0.30	Male 5/16 BSW	HD Steel	1
778B	16	0.30	Male 5/16 BSW	Brass	1
779B	19	0.30	Male 5/16 BSW	Brass	1
780B	25	0.30	Male 5/16 BSW	Brass	1
781B	32	0.30	Male 5/16 BSW	Brass	1
778N	16	0.40	Male 5/16 BSW	Nylon	1
779N	19	0.40	Male 5/16 BSW	Nylon	1
780N	25	0.40	Male 5/16 BSW	Nylon	1
781N	32	0.40	Male 5/16 BSW	Nylon	1



OG2

## Oil Gallery Brushes

For the removal of rust and residue from inside tubes and holes.



Part No.	Dia.	Brush Length	Overall Length	Inner QTY
OG1	6	63	425	1
OG2	9	100	425	1
OG3	13	100	425	1
OG4	19	100	775	1
OG5	25	150	850	1
OG6	106	150	450	1
OG7	19	150	1250	1

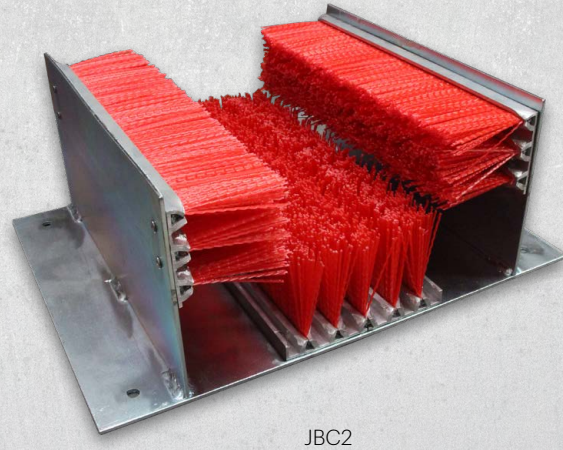
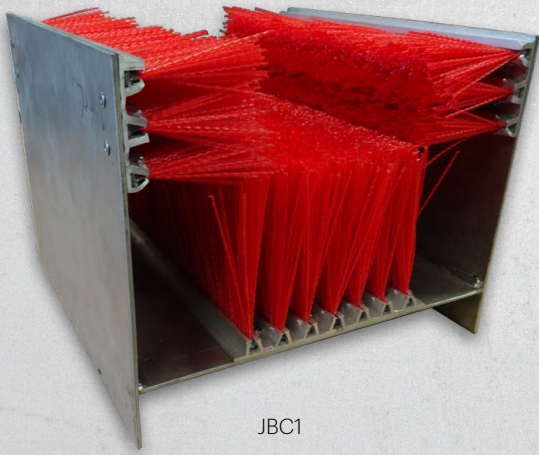

## Boot Cleaners

Part No.	Frame	Brushes	Weight	Inner QTY	Outer QTY	Pack Type
572	Zinc Plated Tube (Light Duty)	2 Side x 4 Bottom	2kg	1	1	Box
JBC1	Galvanised Steel (H-Frame)	3 Side x 7 Bottom	9kg	1	1	Box
JBC2	Galvanised Steel (Flat Base)	3 Side x 7 Bottom	9kg	1	1	Box



## Wheel & Bevel Brush Outside Diameter

Outside diameter (OD) is the overall diameter of the wheel or bevel brush. The diameter of the brush required will depend largely on the tool being used and the job being performed.

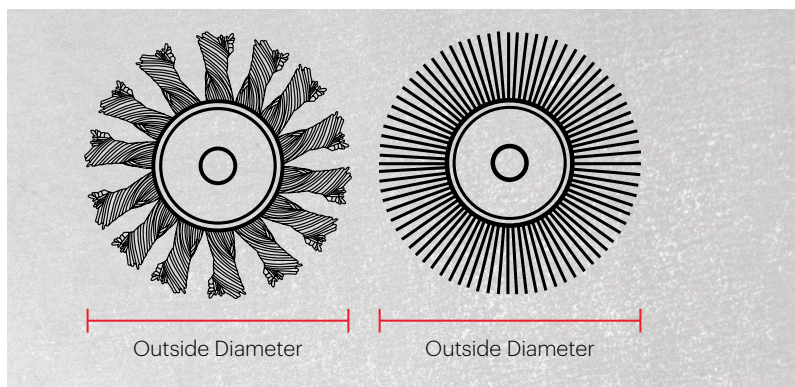

## Wheel & Bevel Brush Inside Diameter & Side plate

Inside diameter (ID) is the diameter of the side plate or flange. The ratio between the inside diameter of the brush and outside diameter of the brush will affect the trim length of the wire in the brush. A shorter trim length will result in a more densely filled brush.

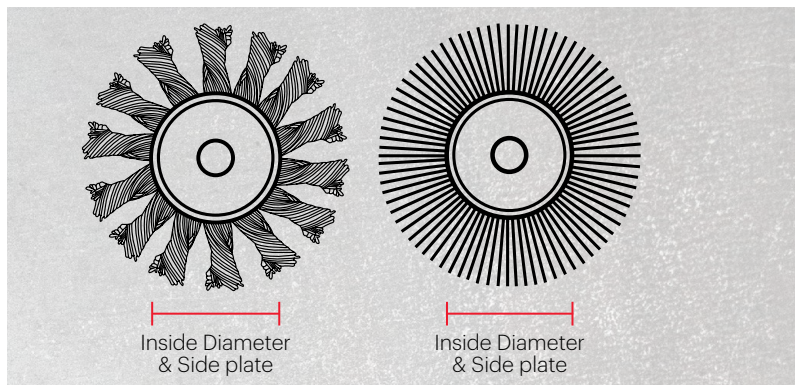

## Wheel Brush Width & Density

Width and density will have the most impact on the effectiveness of the brush. A brush with greater width and density will be more aggressive at removing material. The width of the brush refers to the distance from one edge of the brush to the other when viewed on edge (see diagram). The density of the brush refers to the number of wires in the brush, and a brush with a shorter trim length will have a higher density of wire.

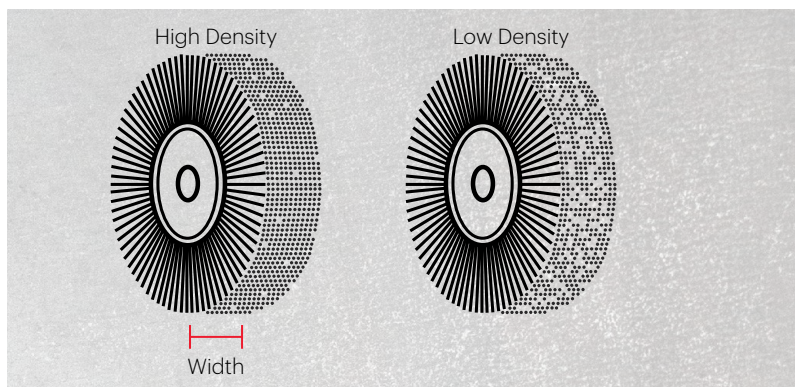

## Bore & Threaded Centre

Sideplates contain a bore or threaded centre to allow the brush to be easily mounted to the tool they are being used on. Most Josco wheel brushes have multi-bore adaptors to allow them to be fitted to all bench grinders. Wheel brushes designed for use with angle grinders will have a threaded centre or bore appropriate for the shaft size of the grinder to be used.

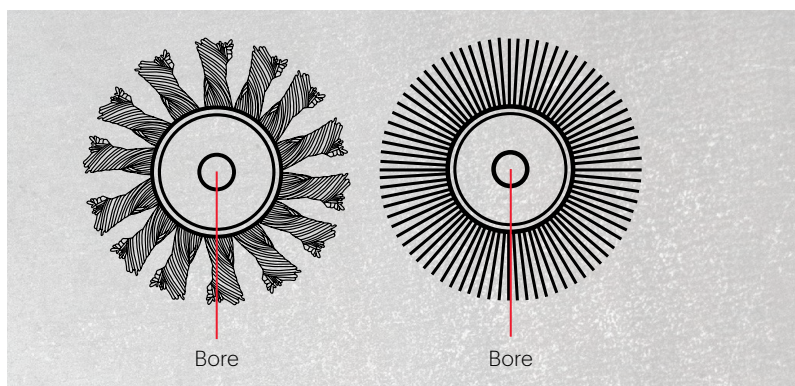



## Bevel Brushes

Bevel Brushes can be used on edge to get into harder to reach areas such as corners and seams, as well as on flat surfaces. The bevel also helps keep the brush away from the guard of the angle grinder.

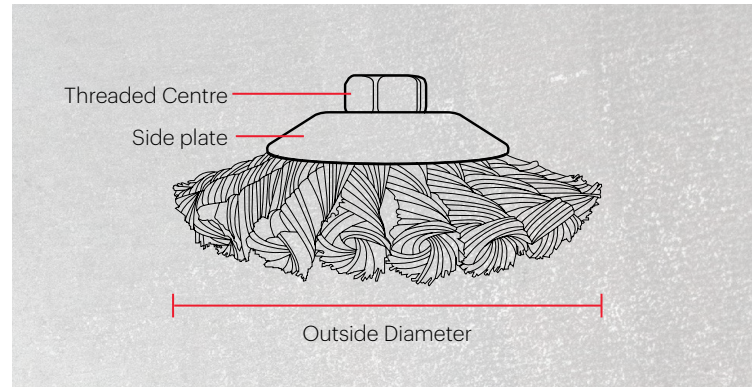

## Cup Brushes

Cup Brushes are designed for use primarily with angle grinders or automated machines, and best suited to be used on flat surfaces.

**Metal Skirt:** Some cup brushes have a metal skirt, which allows the brush to have a longer trim length, extending the life of the brush. Refer to Cup Brush section for detail on how to remove the skirt.

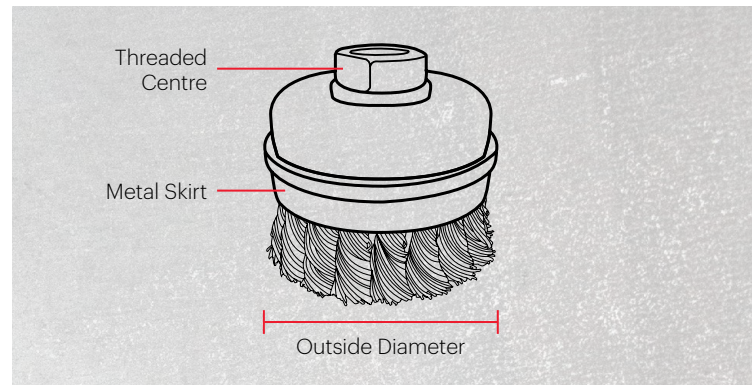

## Spindle Mounted Brushes

Designed for use in drills and die grinders, spindle mounted brushes are often used to get into tighter spaces due to their longer reach. Spindle diameter varies depending on the tool to be used. 6mm or 6.3mm(1/4") shanks are standard sizes and can be used in drills or die grinders (check speed rating), while some larger brushes require a larger diameter spindle that can only be used in drills. Hex shank spindles can only be used in drills, and many can be used with quick change adaptors.

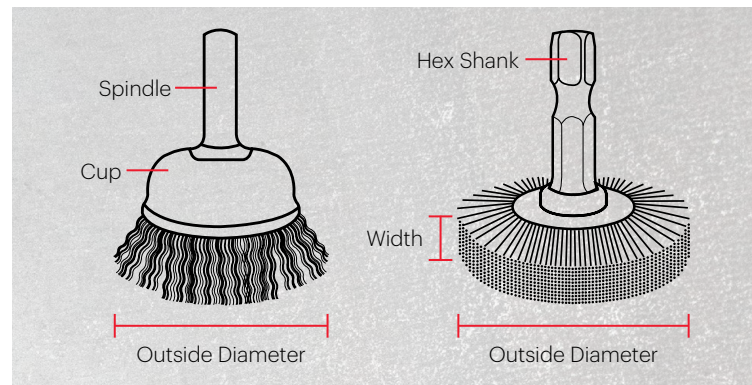

## Tube Brushes

Tube Brushes are ideal for use when deburring or removing foreign material from the inside of pipes and tubes. The ferrule fitting allows the brush to be used with handles, extension adaptors, and drills.

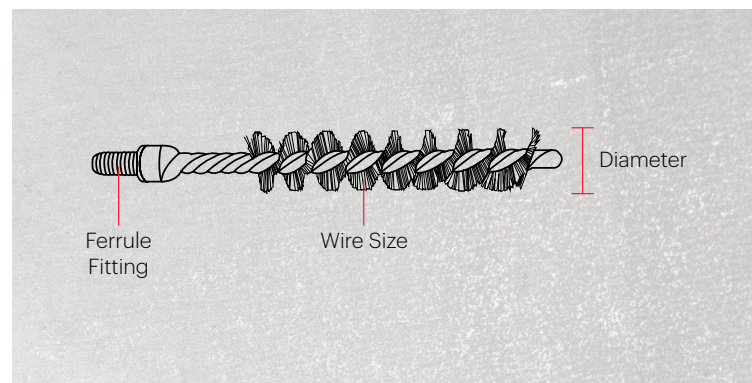



## Wire Types

**Straight wire** can be used in twist knots and tube brushes. When gathered as a collection of straight wires as in hand brushes and some decarb brushes, the straight wire is more capable of getting into narrow slots and other tight spaces.

Used in many different brush configurations, the **crimped wire** is less aggressive and more flexible than the twist knot making it ideal for contoured surfaces.

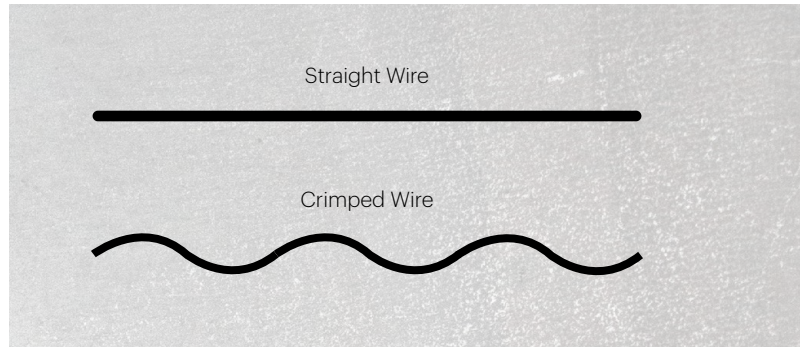

## Knot Types

### Cable Twist Loose End

A standard twist knot configuration, the knot is twisted 2/3 of its length.

### Cable Twist Tight End

A more rigid twist knot suitable for more aggressive material removal the knot is twisted along its full length.

### Stringer Bead

A narrower knot specifically suited for cleaning out the root welds in pipeline welding, this knot configuration is ideal for aggressively cleaning other hard to reach areas.

### Pipeline Twist

A robust knot that is twisted beyond its intended length and then trimmed to produce a very tight strong knot ideally suited to aggressive cleaning of pipeline welds.

### Tiger Claw

A durable twist knot that is twisted its entire length and finished with a tiger claw twist, giving the knot more strength.

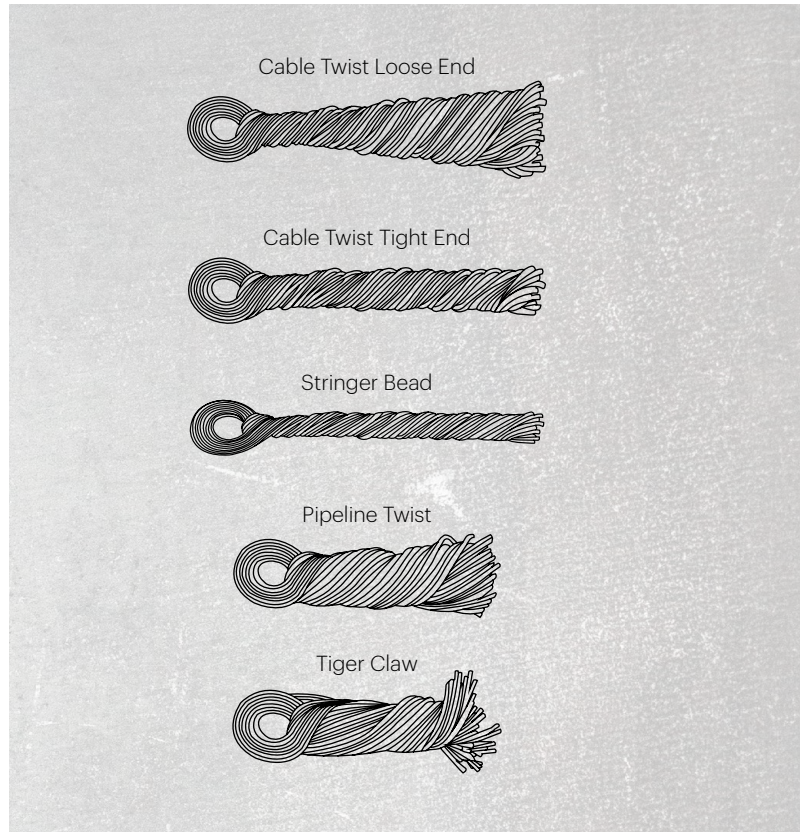

## Brushing Speed and Pressure

Recommended operating speeds vary greatly depending on the brush and its intended use. For cleaning, roughing and de-burring at high speeds, use a light pressure. For finishing, polishing and brushing at low speeds with wire, sufficient pressure may be needed to bring the sides of the wire in contact with the work. Do not exceed the brush's maximum recommended RPM.

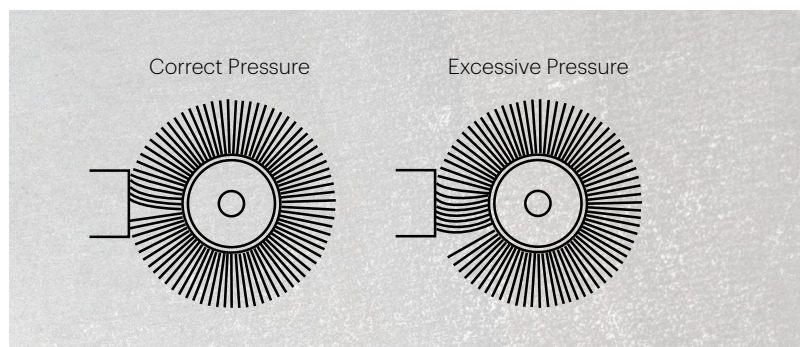

Desired Effect/Problem	Course of Action Advised/Solution
<b>To cut faster</b>	<ul style="list-style-type: none"> <li>• Use a large diameter brush</li> <li>• Increase RPM</li> <li>• Use a brush with a heavier wire gauge</li> <li>• Use a shorter trim</li> </ul> <p>The trim of the brush is the free length wire protruding from the side plates.</p>
<b>To produce a finer finish</b>	<ul style="list-style-type: none"> <li>• Use a brush with a lighter wire gauge</li> <li>• Follow up with Josco polishing mops and compounds</li> </ul>
<b>To reach all parts of an irregular surface</b>	<ul style="list-style-type: none"> <li>• Use a brush with a longer trim</li> </ul>
<b>To remove burrs</b>	<ul style="list-style-type: none"> <li>• Use a short trim wire brush</li> </ul>
<b>To produce a more even finish</b>	<ul style="list-style-type: none"> <li>• Use a holding fixture, hand operated or automatic</li> </ul>

**For more information regarding brushing techniques and how-to's, refer to the resources page of the Josco website at [www.josco.com.au](http://www.josco.com.au). If you have any suggestions of videos, or more questions on how to get the best use out of your Josco brush, please contact us at [customerservice@josco.com.au](mailto:customerservice@josco.com.au) or call 1800 445 444.**

Disclaimer: All recommendations specified in the Josco Brush Catalogue are suggestions for use only. Josco will hold no responsibility for misuse of product where a specified warning is featured in the catalogue or on the products' packaging.



## Flap Disc Backing

### Plastic Backed

The benefit of a plastic backing is that it can be trimmed to increase the working life of the flap disc, which is particularly helpful when it comes to blending and finishing.

## Types of Grit

### Aluminium Oxide

The Aluminium Oxide grit is a blunt abrasive that produces a cost effective flap disc or flap wheel. It removes stock well, and produces a smooth and chatter-free finish.

### Zirconia

Zirconia is a sharper abrasive than Aluminium Oxide, and is ideal for general purpose grinding applications. It cuts cooler and quicker with less effort required.

### Glass Fibre Backed

This is the most popular style of backing for Flap Discs as they help to absorb vibration experienced when in use with no smearing. They are a very strong and durable option that won't contaminate the surface of your work piece.

### Ceramic

Grinding accessories using Ceramic grit are the most premium products in the range, and produce the sharpest finish with a chiseled effect. Stock disappears quickly and efficiently and is easy to use as less effort is required. Ceramic grits deliver a smooth and flat finish with minimal chatter.

### Silicon Carbide

This grit is ideal for the most aggressive stock removal applications, as silicon carbide is one of the hardest materials available on the market. It is ideal for concrete, granite, marble and ceramics.

## Safety Information

For all Josco Abrasive products in this catalogue, please pay close attention to all safety information and cautions featured on the product and packaging. On most Josco packages, you will find a combination of the below safety icons that will give you an indication of what safety precautions you should be taking.

If you have any questions about individual products, please contact the Josco customer service team at [customerservice@josco.com.au](mailto:customerservice@josco.com.au) or call 03 8794 4300.



Wear Ear Protection



Wear Eye Protection



Wear a Mask



Wear Protective Gloves



Refer to Instruction Manual/Pack Instructions



Do Not Use if Damaged



JDC11540



JDC12780



JDZ10040



JDZ11540



JDZ12740

## Ceramic Flap Discs



Ceramic Flap Discs are excellent for fast, aggressive stock removal and metal finishing. The discs cut 40 times faster and last longer than conventional grits, and are ideal for weld preparation and weld seam removal. All Josco Ceramic Flap Discs are Made in EU to EN standards.

Part No.	Material	Diameter	Bore	Grit	Max RPM	Inner QTY	Outer QTY	Pack Type
JDC11540	Ceramic	115mm	22,23mm	40	13,300	3	60	Single Disc
JDC11560	Ceramic	115mm	22,23mm	60	13,300	3	60	Single Disc
JDC11580	Ceramic	115mm	22,23mm	80	13,300	3	60	Single Disc
JDC12740	Ceramic	127mm	22,23mm	40	12,250	3	60	Single Disc
JDC12760	Ceramic	127mm	22,23mm	60	12,250	3	60	Single Disc
JDC12780	Ceramic	127mm	22,23mm	80	12,250	3	60	Single Disc

## Zirconia Flap Discs



Zirconia Flap Discs are ideal for general purpose applications such as weld removal, grinding and clean-up of steel, stainless steel and aluminium, and are great for removing paint and varnish. Finer grits are more suitable for finishing timber prior to painting. They can also be used on cast iron. Zirconia grit is ideal for fast grinding and longer life.

Part No.	Material	Diameter	Bore	Grit	Max RPM	Inner QTY	Outer QTY	Pack Type
JDZ10040	Zirconia	100mm	16mm	40	15,300	5	200	Single Disc
JDZ10060	Zirconia	100mm	16mm	60	15,300	5	200	Single Disc
JDZ10080	Zirconia	100mm	16mm	80	15,300	5	200	Single Disc
JDZ100120	Zirconia	100mm	16mm	120	15,300	5	200	Single Disc
JDZ11540	Zirconia	115mm	22mm	40	13,300	5	200	Single Disc
JDZ11560	Zirconia	115mm	22mm	60	13,300	5	200	Single Disc
JDZ11580	Zirconia	115mm	22mm	80	13,300	5	200	Single Disc
JDZ115120	Zirconia	115mm	22mm	120	13,300	5	200	Single Disc
JDZ12740	Zirconia	127mm	22mm	40	12,000	5	200	Single Disc
JDZ12760	Zirconia	127mm	22mm	60	12,000	5	200	Single Disc
JDZ12780	Zirconia	127mm	22mm	80	12,000	5	200	Single Disc
JDZ127120	Zirconia	127mm	22mm	120	12,000	5	200	Single Disc



JPD125C

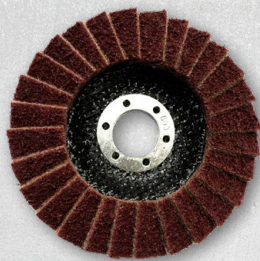

JPD125M



JPD125F

## Poly Flap Discs



Josco Poly Flap Discs are made from a non-woven abrasive cloth and are ideal for removing rust from steel surfaces, cleaning up and removing paint from steel, stainless steel and aluminium, cleaning and finishing of TIG weld seams, polishing stainless steel, and light deburring & de-scaling on steel.

Dependent on the hardness and application, they are available in colour coded coarse (yellow), medium (brown) and fine (blue).

Part No.	Diameter	Bore	Grit	Max RPM	Inner QTY	Outer QTY	Pack Type
JPD100F	100mm	16mm	Fine	15,300	3	60	Clamshell
JPD100M	100mm	16mm	Medium	15,300	3	60	Clamshell
JPD100C	100mm	16mm	Coarse	15,300	3	60	Clamshell
JPD115F	115mm	22mm	Fine	13,300	3	60	Clamshell
JPD115M	115mm	22mm	Medium	13,300	3	60	Clamshell
JPD115C	115mm	22mm	Coarse	13,300	3	60	Clamshell
JPD125F	125mm	22mm	Fine	12,200	3	60	Clamshell
JPD125M	125mm	22mm	Medium	12,200	3	60	Clamshell
JPD125C	125mm	22mm	Coarse	12,200	3	60	Clamshell



## Contour Sander



**Eliminate hand sanding on curved, fluted or flat surfaces – matt down paint or varnish between coats.**

- Individual flaps mould to contours of work piece
- Long shaft is ideal for reaching awkward places
- Sand the flutes of radiators and garage doors
- Prepare louvers prior to painting
- Renovate furniture

Two speed power tools should be used, with the highest speed for sanding and stripping, and the lowest speed for light finish and smoothing. Maximum recommended speed is 4,000 RPM and recommended minimum speed is 1,000 RPM. Do not use excessive pressure. Let the contour sander do the work. A coarse grade should be selected for more aggressive sanding operations.

### Common Applications & General Information:

The Josco Contour Sander is ideal for decorating, renovating or restoration jobs. Save hours of hand sanding on curved or irregular shaped wood and metal surfaces.

- Use to sand doors, skirtings and architraves prior to painting
- Renovate/restore wood furniture and prepare for varnishing
- Sand carvings and sculptures

## Technical Information

Because of the large number of flaps which Flap Wheels contain, they are very economical compared with belts etc, reducing finishing costs, due to the longer life and reduced downtime.

### Examples of application for Flap Wheels:

- Finishing of stainless steel vessels
- De-scaling heat treated aluminium
- Removing machine marks and flaws from castings
- Sanding wood, prior to painting
- Grinding off fibreglass flash and sharp mould edges
- Polishing and finishing the convex and concave surfaces of tubular steel (the wheel will wear to match the contours of the tubing)
- Polishing aluminium – even fine grits do not clog
- Removing flash from rubber and plastic
- Cleaning up welds, scratches and rust from fabricated parts
- Removing surface blemishes or excess glaze from ceramics
- Grinding and scuffing leather in shoe-making and repairing
- Removing rust and sharpening tools
- Removing burrs and giving satin finish to metals
- Grinding out imperfections on steel forgings

### How to obtain the best performance

- Use only light pressure so that only the tips of the flaps are in contact with the work piece.
- Flap wheels give a finer effect and last considerably longer if they are used with a grinding paste or grease.
- If the rate of stock removal is insufficient, use a coarser grit.
- When using Flap Wheels on a moving or rotating workpiece, the movement of the work piece must be in the opposite direction to the rotation of the wheel.
- ALWAYS observe the maximum recommended RPM given in the tables.



### Part No: CONTOURCOURSE

Sander: 125mm (5") diameter  
38mm (1 1/2") wide  
Shaft: 6mm (1/4") diameter  
113mm (4 1/2") long



FW3015040C



FW5020080C



FW6030040C



FW8030120C

## Premium Flap Wheels



Flap Wheels offer a quick and economical solution to working on both flat and contoured surfaces. The 'Flap Top and Bottom' design allows more versatility of application than 'Raised Hub' versions.

Manufactured using the highest quality industrial cloth, the wheel design is such that as the flaps wear down, new abrasive is continuously exposed. This action prevents clogging and gives a uniform, constant finish throughout the life of the wheel.

Part No.	Diameter	Width	Grit	Max RPM	Inner QTY	Outer QTY	Pack Type
FW3015040C	30mm	15mm	40	25,000	3	60	Clamshell
FW3015060C	30mm	15mm	60	25,000	3	60	Clamshell
FW3015080C	30mm	15mm	80	25,000	3	60	Clamshell
FW30150120C	30mm	15mm	120	25,000	3	60	Clamshell
FW4015040C	40mm	15mm	40	19,000	3	60	Clamshell
FW4015060C	40mm	15mm	60	19,000	3	60	Clamshell
FW4015080C	40mm	15mm	80	19,000	3	60	Clamshell
FW40150120C	40mm	15mm	120	19,000	3	60	Clamshell
FW5020040C	50mm	20mm	40	15,000	3	60	Clamshell
FW5020060C	50mm	20mm	60	15,000	3	60	Clamshell
FW5020080C	50mm	20mm	80	15,000	3	60	Clamshell
FW50200120C	50mm	20mm	120	15,000	3	60	Clamshell
FW6030040C	60mm	30mm	40	12,600	3	60	Clamshell
FW6030060C	60mm	30mm	60	12,600	3	60	Clamshell
FW6030080C	60mm	30mm	80	12,600	3	60	Clamshell
FW60300120C	60mm	30mm	120	12,600	3	60	Clamshell
FW8030040C	60mm	30mm	40	9,500	3	60	Clamshell
FW8030060C	60mm	30mm	60	9,500	3	60	Clamshell
FW8030080C	60mm	30mm	80	9,500	3	60	Clamshell
FW80300120C	60mm	30mm	120	9,500	3	60	Clamshell

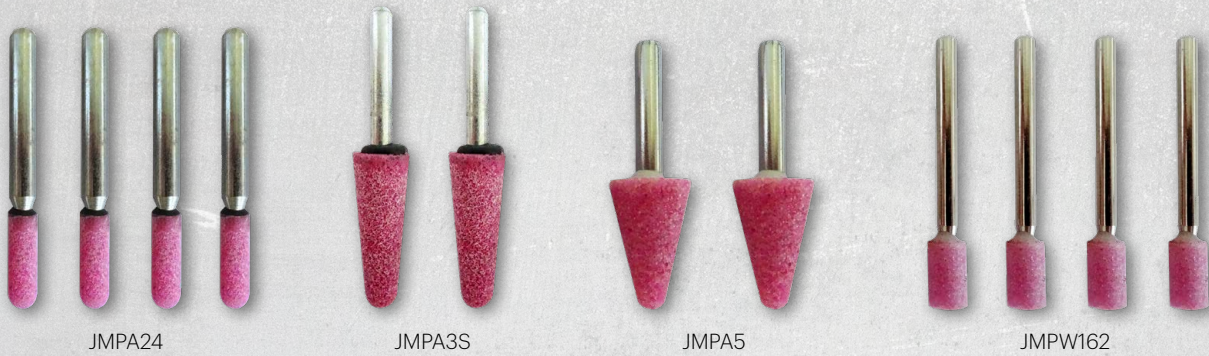

## Mounted Point Kits

Abrasive Mounted Points are made from pink aluminium oxide and are ideal for grinding and finishing on stainless steel, cast iron and high alloy steel.



Part No.	Description	Shank	Pack Size	Inner QTY	Outer QTY	Pack Type
JMPK5	MPA3S: A3S 16 x 45mm MPA5: A5 19 x 28mm MPA24: A24 6 x 19mm MPA26: A26 16 x 16mm MPW177: W177 10 x 19mm	6mm	5	10	100	Clamshell
JMPK5M	MPB44: B44 6 x 10mm MPB92: B92 6 x 6mm MPB97: B97 3 x 10mm MPB123: B123 5 x 5mm MPW162: W162 6 x 10mm	3mm	5	10	300	Clamshell
JMPA1	A1 19 x 63mm	6mm	2	10	100	Clamshell
JMPA11	A11 22 x 50mm	6mm	2	10	100	Clamshell
JMPA12	A12 18 x 32mm	6mm	2	10	100	Clamshell
JMPA24	A24 6 x 19mm	6mm	4	10	300	Clamshell
JMPA3	A3 25 x 70mm	6mm	2	10	100	Clamshell
JMPA3S	A3S 16 x 45mm	6mm	2	10	100	Clamshell
JMPA5	A5 19 x 28mm	6mm	2	10	100	Clamshell
JMPW162	W162 6 x 10mm	6mm	4	10	300	Clamshell
JMPW177	W177 10 x 19mm	6mm	4	10	300	Clamshell
JMPW189	W189 13 x 50mm	6mm	2	10	300	Clamshell
JMPW208	W208 19 x 51mm	6mm	2	10	100	Clamshell
JMPW220	W220 25 x 25mm	6mm	2	10	100	Clamshell
JMPW228	W228 32 x 19mm	6mm	2	10	100	Clamshell
JMPW232	W232 32 x 50mm	6mm	1	10	100	Clamshell
JMPW242	W242 50 x 25mm	6mm	1	10	100	Clamshell



## Maximum Operating Speeds

Maximum operating speeds are dependent on the shape and size of wheel, the size of the shank and the amount of overhang. The table of speeds given below for Josco's range of mounted points is based on a maximum overhang 'O' of 1/2" (13mm).

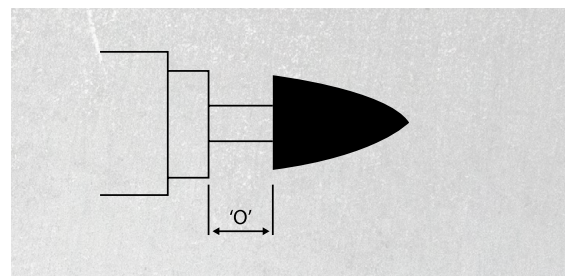

**Table of maximum permissible operating in RPM using an overhang 'O' of no more than 1/2" (13mm).**

Shape No.	M.O.S (RPM)	Shape No.	M.O.S (RPM)	Shape No.	M.O.S (RPM)	Shape No.	M.O.S (RPM)
A1	19,800	B41	33,750	W144	105,000	W196	32,250
A2	38,000	B42	33,750	W145	105,000	W197	21,000
A3	16,100	B44	68,400	W146	105,000	W200	47,750
A3S	17,000	B46	105,000	W152	105,000	W201	47,750
A4	29,840	B52	45,370	W153	80,850	W203	47,750
A5	45,000	B53	60,000	W154	70,000	W204	42,750
A11	19,860	B62	41,020	W160	81,370	W205	34,500
A12	48,000	B71	59,680	W162	68,400	W207	24,000
A13	33,950	B81	47,750	W163	60,000	W208	18,750
A14	53,050	B91	34,500	W164	45,900	W215	38,200
A15	72,750	B92	81,370	W170	55,000	W216	38,200
A21	34,500	B97	105,000	W175	54,000	W218	38,200
A23	39,370	B98	105,000	W176	45,370	W220	25,500
A24	76,500	B101	33,750	W177	66,000	W222	15,900
A25	35,620	B103	59,680	W178	55,200	W226	29,840
A26	59,680	B104	68,400	W179	45,000	W227	29,840
A31	27,260	B121	45,370	W182	73,460	W228	29,840
A32	38,200	B122	61,650	W185	61,500	W230	20,400
A33	38,000	B123	104,250	W186	51,000	W232	14,250
A34	25,130	B131	34,500	W187	40,000	W236	25,130
A35	38,200	B132	45,370	W188	30,370	W242	19,100
A36	23,520	B133	54,000	W189	20,000		
A37	29,840	B135	60,000				
A38	34,500						
A39	47,250						

If an overhang of more than 1/2" (13mm) is used, the maximum permissible operating speeds are reduced. See the Health and Safety Executive publication ref. HS(G) 17 and the European Safety Co. issued by the Federation of European Producers of Abrasive Products (FEPA NO 12GB74).

### Important Safety Instructions

1. Do not exceed the maximum permissible operating speeds and overhang of points.
2. Always wear eye protection.
3. Check that the bearings and collet of your grinder are not worn.
4. Avoid excessive pressure which could damage the mandrel.

## Safety Information

For all Josco polishing products in this catalogue, please pay close attention to all safety information and cautions featured on the product and packaging. On most Josco packages you will find a combination of the below safety icons that will give you an indication of what safety precautions you should be taking.

If you have any questions about individual products, please contact the Josco customer service team at [customerservice@josco.com.au](mailto:customerservice@josco.com.au) or call 03 8794 4300.



Wear Ear Protection



Wear Eye Protection



Wear a Mask



Wear Protective Gloves



Refer to Instruction Manual/Pack Instructions



Do Not Use if Damaged

## Selecting the correct Josco Compound & Buff

Compund	Buff	Finish
SS	Loose Leaf Calico	High quality finish on aluminium alloys
SSX	Loose Leaf Calico	High gloss finish on copper, brass and stainless steel
Multishine	Loose Leaf Calico	High gloss finish on plastics and die-cast articles
Tripoli	Stitched Rag	General purpose compound for copper, brass, aluminium and most metals
Fastcut	Sisal	To cut back light stretch marks on copper, brass and stainless steel prior to polishing

## Techniques for using Josco Compounds & Buffs

### Step 1

Always use safety goggles or eye protection.

### Step 2

All buffs have tapered centre bores and may be mounted on the left or right side of your grinder using a Josco tapered spindle.

### Step 3

Select the correct buff for your job – refer to the above chart for details.

### Step 4

Never use different compounds on one buff – keep a separate buff for each compound.

### Step 5

Dress the buff with compound across the face of the rotating wheel for a few seconds, taking care not to apply too much compound which will overload the buff. It is far better to apply a small amount of compound more frequently than to over dress the buff.

### Step 6

After dressing the buff, bring the work piece into contact with light pressure, moving back and forth across the work piece.

### Step 7

After polishing, remove any residue with mineral turpentine or methylated spirits. Warm soapy water will also work.

## Buffing Wheel Speed Chart

RPM	Diameter of Buffing Wheels in Inches										
	4	6	8	10	12	14	16	18	20	22	24
	Surface Speed in Feet per Minute										
800	837	1256	1675	2094	2513	2932	3351	3770	4189	4608	5026
900	942	1413	1885	2356	2827	3298	3770	4241	4712	5184	5655
1000	1047	1570	2094	2618	3141	3665	4189	4712	5236	5760	6283
1100	1152	1727	2304	2880	3455	4031	4608	5183	5760	6336	6911
1200	1256	1884	2513	3142	3769	4398	5027	5655	6283	6912	7540
1300	1361	2042	2723	3404	4084	4764	5446	6126	6807	7488	8168
1400	1466	2199	2932	3666	4398	5131	5865	6597	7330	8064	8796
1500	1571	2356	3142	3927	4712	5497	6284	7069	7854	8640	9425
1600	1675	2513	3351	4189	5026	5864	6703	7540	8378	9216	10053
1700	1780	2670	3560	4451	5340	6230	7121	8011	8901	9792	10681
1800	1885	2827	3770	4713	5654	6597	7540	8482	9425	10368	11310
1900	1989	2984	3979	4975	5969	6963	7959	8954	9948	10944	11938
2000	2094	3141	4189	5236	6283	7330	8378	9425	10472	11520	12566
2100	2199	3298	4398	5498	6597	7696	8797	9896	10996	12096	13194
2200	2304	3455	4608	5760	6911	8063	9215	10367	11519	12672	13822
2300	2408	3612	4817	6022	7225	8429	9634	10839	12043	13248	14451
2400	2513	3770	5027	6284	7540	8796	10053	11310	12566	13824	15079
2500	2618	3927	5236	6545	7854	9162	10471	11781	13090	14400	15708
2600	2722	4084	5445	6807	8168	9529	10890	12253	13613	14976	16336
2700	2827	4241	5655	7069	8482	9895	11309	12724	14136	15552	16964
2800	2932	4398	5864	7331	8796	10262	11728	13196	14660	16128	17592
2900	3037	4555	6074	7592	9110	10629	12147	13667	15184	16704	18221
3000	3141	4712	6283	7854	9425	10996	12566	14137	15708	17280	18550





## Polishing Compounds



Josco Polishing Compounds are used on surfaces without major blemishes, resulting in little metal removal and a bright result. Small scratches produced by cutters can easily be removed by subsequent use of a finishing compound. Polishing Compounds are used with either a stitched rag or loose leaf calico buff.

Part No.	Description	Size	Colour	Inner QTY	Outer QTY	Pack Type
SSJ	High quality finish for Aluminium and Aluminium Alloys	Large	White	2	20	Clamshell
SSXJ	High gloss finish on Copper, Brass, Stainless Steel – always use loose leaf buff	Large	Light Green	2	20	Clamshell
MULTISHINEJ	High gloss finish for all Plastics, Gold, Silver and Die Cast articles	Large	Light Blue	2	20	Clamshell
FASTCUTJ	Removing 240 Grit belt marks from Steel prior to plating and removal of heat scale and scratches on Stainless Steel Also for cutting back on Brass and Copper	Large	Dark Grey	2	20	Clamshell
TRIPOLIJ	General purpose Compound for Stainless Steel, Copper and Brass	Large	Brown	2	20	Clamshell



JLCO500



JLCO500



JVGPWC



JVGPWM

## Lapping Compounds

Josco's range of lapping compounds comprise of an abrasive grain mixed with either water or oil as a fluid/paste as a suitable carrier medium. They are ideal for use in finishing processes for flat, cylindrical and spherical workpieces.

All Josco Lapping Compounds are made in Australia.

Part No.	Description	Weight	Grit	Inner QTY	Pack Type
JLCO120	Oil Fluid	500g NET	120	1	Plastic Tub
JLCO320	Oil Fluid	500g NET	320	1	Plastic Tub
JLCO500	Oil Fluid	500g NET	500	1	Plastic Tub
JLCO700	Oil Fluid	500g NET	700	1	Plastic Tub
JLCW120	Water Fluid	500g NET	120	1	Plastic Tub
JLCW240	Water Fluid	500g NET	240	1	Plastic Tub
JLCW320	Water Fluid	500g NET	320	1	Plastic Tub
JLCW500	Water Fluid	500g NET	500	1	Plastic Tub
JLCW700	Water Fluid	500g NET	700	1	Plastic Tub

## Valve Grinding Paste

Valve Grinding Paste's are designed to lap hardened engine poppet valves, and may also be used in many other grinding applications where a sharp abrasive media is required. The water mixed variation is for fast grinding, and the oil mix is for precision grinding.

All Josco Valve Grinding Paste is made in Australia.

Part No.	Description	Weight	Grit	Inner QTY	Pack Type
JVGPOF	Oil Mixed	500g NET	Fine	1	Plastic Tub
JVGPOM	Oil Mixed	500g NET	Medium	1	Plastic Tub
JVGPOC	Oil Mixed	500g NET	Coarse	1	Plastic Tub
JVGPWF	Water Mixed	500g NET	Fine	1	Plastic Tub
JVGPWM	Water Mixed	500g NET	Medium	1	Plastic Tub
JVGPWC	Water Mixed	500g NET	Coarse	1	Plastic Tub





## Sisal Buffs

Josco Sisal Buffs are manufactured from alternate layers of heavy calico and sisal cloth tightly stitched together to the desired thickness. They are suitable for the preparation of polishing surfaces with excellent cutting power when used together with a Fastcut compound, and a tapered spindle when fitting onto a bench grinder.



Part No.	Description	Diameter	Sections	Inner QTY	Outer QTY	Pack Type
JSZ15050	Stitched Sisal Buff	150mm	1 Section - 13mm	2	30	Clamshell
JSZ150100	Stitched Sisal Buff	150mm	2 Section - 26mm	2	30	Clamshell
JSZ20050	Stitched Sisal Buff	200mm	1 Section - 13mm	2	20	Clamshell
JSZ200100	Stitched Sisal Buff	200mm	2 Section - 26mm	2	20	Clamshell



## Stitched Rag Buffs

Stitched Rag Buffs are a general purpose mop where high pressure can be exerted, especially when cutting. They are suitable for polishing metals, plastic, aluminium, stainless steel, copper, brass, chrome, silver, gold and alloys.



Part No.	Description	Diameter	Sections	Inner QTY	Outer QTY	Pack Type
JST15050	Stitched Rag Buff	150mm	1 Section - 13mm	2	30	Clamshell
JST150100	Stitched Rag Buff	150mm	2 Section - 26mm	2	30	Clamshell
JST20050	Stitched Rag Buff	200mm	1 Section - 13mm	2	20	Clamshell
JST200100	Stitched Rag Buff	200mm	2 Section - 26mm	2	20	Clamshell



JSC15050



JSC150100



JSC150200



JSC200100

## Stitched Calico Buffs



Josco Calico Buffs are formed by the unsewing of pure cotton cloth. They are universal buffs for common polishing machinery to polish flat surfaces. They are possibly the best all-round mops suitable for brass, silver, copper, aluminium, chrome and plastics.

Part No.	Description	Diameter	Sections	Inner QTY	Outer QTY	Pack Type
JSC15050	Stitched Calico Buff	150mm	50 Fold – 18mm	2	30	Clamshell
JSC150100	Stitched Calico Buff	150mm	100 Fold – 36mm	2	30	Clamshell
JSC150200	Stitched Calico Buff	150mm	200 Fold – 72mm	2	30	Box
JSC200100	Stitched Calico Buff	200mm	100 Fold – 36mm	2	20	Clamshell
JSC200200	Stitched Calico Buff	200mm	200 Fold – 72mm	2	20	Box



JLL150100



JLL150150



JLL150200



JLL200100



JLL200200

## Loose Leaf Calico Buffs



Josco Calico Buffs are formed by the unsewing of pure cotton cloth. They are universal buffs for common polishing machinery to polish flat surfaces. They are possibly the best all-round mops suitable for brass, silver, copper, aluminium, chrome and plastics.

Part No.	Description	Diameter	Sections	Inner QTY	Outer QTY	Pack Type
JLL15050	Loose Leaf Calico Buff	150mm	50 Fold – 18mm	2	30	Clamshell
JLL150100	Loose Leaf Calico Buff	150mm	100 Fold – 36mm	2	30	Clamshell
JLL150150	Loose Leaf Calico Buff	150mm	150 Fold – 54mm	2	30	Box
JLL150200	Loose Leaf Calico Buff	150mm	200 Fold – 72mm	2	30	Box
JLL20050	Loose Leaf Calico Buff	200mm	50 Fold – 18mm	2	20	Box
JLL200100	Loose Leaf Calico Buff	200mm	100 Fold – 36mm	2	20	Clamshell
JLL200150	Loose Leaf Calico Buff	200mm	150 Fold – 54mm	2	20	Box
JLL200200	Loose Leaf Calico Buff	200mm	200 Fold – 72mm	2	20	Clamshell

Other sizes and formulations available upon request.  
Please contact us at customerservice@josco.com.au or call us on 03 8794 4300.





JFPD127

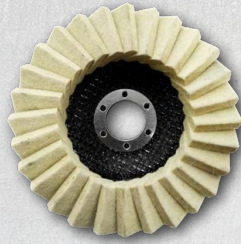

JFPD127

## Felt Polishing Disc



New from Josco, the felt polishing flap disc is an excellent quick-change polishing tool, made from a soft felt for use with Josco polishing compounds. It is to be used with a variable speed angle grinder or sander/polisher. For optimum performance, Josco has thoroughly tested the product in various applications to find the best results were achieved at a maximum RPM of 4,500.

Part No.	Description	Diameter	Bore	Inner QTY	Outer QTY	Pack Type
JFPD127	Felt Polishing Disc	127mm	22mm	3	60	Single Disc



JPK1



JPK2



JRPK50



JRPK100



JMPKIT5

## Metal Polishing Kits



Josco Metal Polishing Kits are ideal for polishing aluminium, brass, steel, stainless steel, copper and most metals including: mag wheels, engine and exhaust parts, bull bars and golf clubs.

Kits come complete with buff and compound combination for cutting back light scratches and corrosion, and buff and compound combination for polishing to a high mirror finish. All buffs are spindle mounted for ease of use on your drill.

Part No.	Description	Inner QTY	Outer QTY	Pack Type
JPK1	Metal Polishing Kit: 1xSisal Buff, 1xLoose Leaf Calico Buff, 1xFastcut Card, 1xSS Compound	3	60	Clamshell
JPK2	Jumbo Metal Polishing Kit: 1x50mm Sisal Buff, 1x50mm Loose Leaf Calico Buff, 1x100mm Sisal Buff, 1x100mm Loose Leaf Calico Buff, 1xFastcut Compound, 1xSS Compound	3	30	Clamshell
JRPK50	50mm Replacement Buffs: 1x50mm Replacement Sisal Buff, 1x50mm Replacement Loose Leaf Calico Buff	3	30	Clamshell
JRPK100	100mm Replacement Buffs: 1x100mm Replacement Sisal Buff, 1x100mm Replacement Loose Leaf Calico Buff	3	30	Clamshell
JMPKIT5	5 Piece Metal Polishing Kit: 1xSisal Buff, 1xCalico Buff, 1xTapered Loose Leaf Buff, 1xSS Polishing Compound, 1xFastcut Cutting Compound	3	30	Clamshell



## Singles

Josco's Tapered Spindles are suitable for fitting buffs and wheels to bench grinders and sander/polishers. The range includes both metric and imperial variations.



Part No.	Description	Inner QTY	Outer QTY	Pack Type
JTS012L	12mm Left Hand Tapered Spindle	5	50	Clamshell
JTS012R	12mm Right Hand Tapered Spindle	5	50	Clamshell
JTS016L	16mm Left Hand Tapered Spindle	5	50	Clamshell
JTS016R	16mm Right Hand Tapered Spindle	5	50	Clamshell
JTS120L	1/2" Left Hand Tapered Spindle	5	50	Clamshell
JTS120R	1/2" Right Hand Tapered Spindle	5	50	Clamshell
JTS580L	5/8" Left Hand Tapered Spindle	5	50	Clamshell
JTS580R	5/8" Right Hand Tapered Spindle	5	50	Clamshell
JTS142R	14x2mm Right Hand Tapered Spindle	5	50	Clamshell



## Backing Pads

Josco Calico Buffs are formed by the unsewing of pure cotton cloth. They are universal buffs for common polishing machinery to polish flat surfaces. They are possibly the best all-round mops suitable for brass, silver, copper, aluminium, chrome and plastics.



Part No.	Description	Diameter	Inner QTY	Outer QTY	Pack Type
B104110	100mm Backing Pad Rubber M10 with Drill Adaptor	100mm	3	60	Box - Hangsell
B104111	115mm Backing Pad Rubber M14 with Drill Adaptor	115mm	3	60	Box - Hangsell
B104112	125mm Backing Pad Rubber M14 with Drill Adaptor	125mm	3	60	Box - Hangsell
B104113	180mm Backing Pad Rubber M14 with Drill Adaptor	180mm	3	60	Box - Hangsell
J104101	125mm Backing Pad Nylon M14	125mm	3	60	Box - Hangsell
J104103	180mm Backing Pad Nylon M14	180mm	3	60	Box - Hangsell



### Tapered Spindle Fitting Instructions for Bench Grinders

Please take note of maximum RPM's on the product and packaging, and adhere to all safety precautions as specified in the technical information section of this catalogue.



#### Step 1

Remove outer guard, grinding wheel and inner guard from the side of the machine that the tapered spindle is to be fitted to.

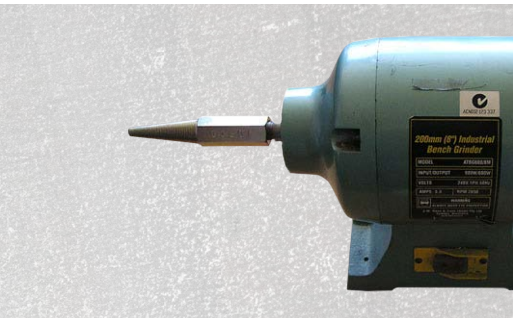

#### Step 2

Screw on the tapered spindle.  
Note: the internal thread of the spindle is counter bored to allow the spindle to cover the entire grinder shaft length.

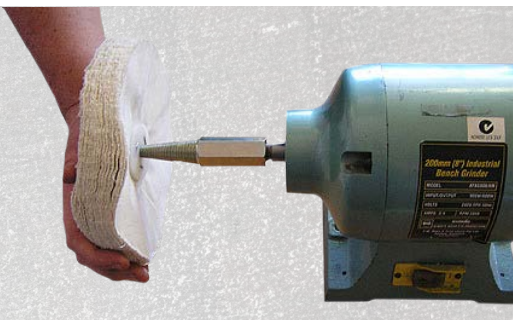

#### Step 3

Carefully screw the buff onto the tapered spindle with the thickest flange facing inwards.  
Screw on as far as the buff will reasonably fit.

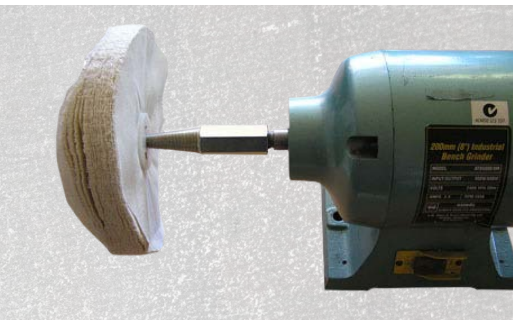

#### Step 4

Turn on bench grinder and the buff will tighten further against the tapered spindle.

### Tapered Spindle Fitting Instructions for Sander/Polishers

#### Step 1

Carefully screw the buff onto the tapered spindle with the thickest flange facing inwards.  
Screw on as far as the buff will reasonably fit.

#### Step 2

Turn on your sander/polisher and the buff will tighten further against the tapered spindle.



**JOSCO**

EST.  
1977

**FOR GENERAL ENQUIRIES AND MORE INFORMATION  
ON JOSCO PRODUCTS, PLEASE CONTACT US AT:**

6 Silkwood Drive, Carrum Downs VIC 3201

P 03 8794 4300 E [customerservice@josco.com.au](mailto:customerservice@josco.com.au)